



DERATED TRIPLE L SHAPED METAL BOTTOM HEATER

Durable, efficient chemical heater. Bottom style, low watt, L-shaped MOTS heater with heavy wall metal sheaths available in steel, 304 stainless steel, 316 stainless steel and titanium. Check solution recommendation chart with your chemical supplier for proper sheath material selection. Single or three phase. 1500-18000 watts, 120-480 volts.



FEATURES

For use in most aqueous alkaline solutions, plating and phosphate tanks. Check solution recommendation chart with your chemical supplier for proper sheath material selection.

Heavy wall metal sheaths available in: steel, 304 stainless steel, 316 stainless steel, titanium.

Watt densities up to 18 watts per square inch (2.7 w/cm²) ensure long service life.

Vapor-resistant, flame retardant polypropylene terminal enclosure with 3 ft (.9m) flexible PVC liquid tight conduit.

Temperature and level controls sized to match the heater.

Lower watt densities for highly viscous solutions.

D3L SERIES, DERATED TRIPLE METAL L-SHAPED HEATERS										
WATTS	VOLTS	STD.		STEEL	304 SS	316 SS	TITANIUM	SHIP WGT.	Lbs./kg)	
		HORIZ. In./(mm)	VERT.* In./(mm)							
1500	120	13	15	D3LP1.5113-R**	D3LF1.5113-R**	D3LS1.5113-R**	D3LT1.5113-R**	30		
	240	(330)	(381)	D3LP1.5213-R**	D3LF1.5213-R**	D3LS1.5213-R**	D3LT1.5213-R**			
3000	240	17	37	D3LP3217-R**	D3LF3217-R**	D3LS3217-R**	D3LT3217-R**	33		
	480	(432)	(940)	D3LP3417-R**	D3LF3417-R**	D3LS3417-R**	D3LT3417-R**			
4500	240	22	37	D3LP4.5222-R**	D3LF4.5222-R**	D3LS4.5222-R**	D3LT4.5222-R**	36		
	480	(559)	(940)	D3LP4.5422-R**	D3LF4.5422-R**	D3LS4.5422-R**	D3LT4.5422-R**			
6000	240	26	37	D3LP6226-R**	D3LF6226-R**	D3LS6226-R**	D3LT6226-R**	39		
	480	(660)	(940)	D3LP6426-R**	D3LF6426-R**	D3LS6426-R**	D3LT6426-R**			
7500	240	31	37	D3LP7.5231-R**	D3LF7.5231-R**	D3LS7.5231-R**	D3LT7.5231-R**	42		
	480	(787)	(940)	D3LP7.5431-R**	D3LF7.5431-R**	D3LS7.5431-R**	D3LT7.5431-R**			
9000	240	36	50	D3LP9236-R**	D3LF9236-R**	D3LS9236-R**	D3LT9236-R**	45		
	480	(914)	(1270)	D3LP9436-R**	D3LF9436-R**	D3LS9436-R**	D3LT9436-R**			
12000	240	44	50	D3LP12244-R**	D3LF12244-R**	D3LS12244-R**	D3LT12244-R**	54		
	480	(1118)	(1270)	D3LP12444-R**	D3LF12444-R**	D3LS12444-R**	D3LT12444-R**			
13500	240	50	50	D3LP13.5250-R**	D3LF13.5250-R**	D3LS13.5250-R**	D3LT13.5250-R**	60		
	480	(1270)	(1270)	D3LP13.5450-R**	D3LF13.5450-R**	D3LS13.5450-R**	D3LT13.5450-R**			
15000	240	55	50	D3LP15255-R**	D3LF15255-R**	D3LS15255-R**	D3LT15255-R**	66		
	480	(1397)	(1270)	D3LP15455-R**	D3LF15455-R**	D3LS15455-R**	D3LT15455-R**			
18000	240	64	50	D3LP18264-R**	D3LF18264-R**	D3LS18264-R**	D3LT18264-R**	75		
	480	(1626)	(1270)	D3LP18464-R**	D3LF18464-R**	D3LS18464-R**	D3LT18464-R**			

Three phase standard

Derated Triple L Shaped Metal Bottom Heater

SPECIFICATIONS

Wattages	1,500 Watts to 18,000 Watts
Voltages	120 Volts to 480 Volts
Options	Special configurations & lengths Longer wire and conduit lengths All metal welded junction box
Safety Features	Grounded construction Thermal protector built in. Replaceable PI protector standard for solutions . See chart below for options

DIMENSIONS

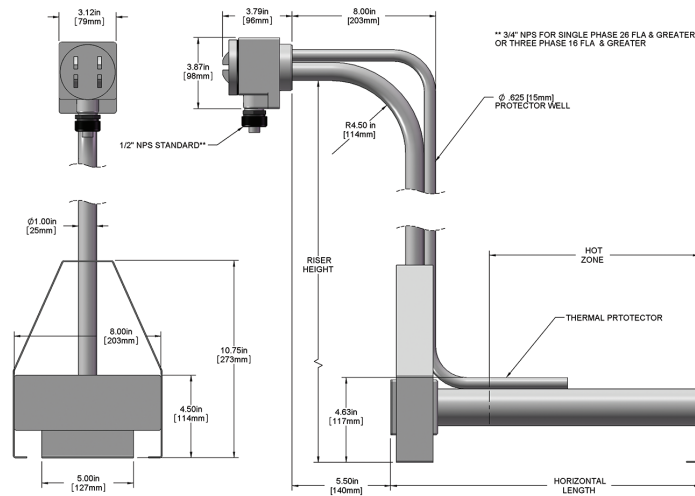

MODEL NUMBER BREAKDOWN

Series	Wattage	Voltage	Horizontal Length (in.)	Vertical Length (in.)	Riser Option	Phase	Type of Protector	Wire & Conduit Length
P = Steel	1.5 = 1500	1 = 120	13 = 1.5kW	-R15 = 1.5kW	Blank = 90° horizontal bend (std)	blank = three phase (std)	Replaceable Fuse	36" length standard (no designator)
F = 304 stainless steel	3 = 3000	2 = 240	17 = 3kW	-R19 = 3kW	S = straight riser	-1 = single phase	P1 (std) = solutions up to 180°F	Specify variations from standard Ex: -X84 = 84"
S = 316 stainless steel	4.5 = 4500	3 = 380	22 = 4.5kW	-R25 = 4.5kW			P4 = solutions up to 230°F	
T = Titanium	6 = 6000	4 = 480	26 = 6kW	-R25 = 6kW			P5 = solutions up to 300°F	
	7.5 = 7500	5 = 415	31 = 7.5kW	-R37 = 7.5kW			Resettable Fuse	
	9 = 9000	6 = 600	36 = 9kW	-R50 = 9kW			P2 = solutions up to 180°F	
	12 = 12000	7 = 400	44 = 12kW	-R50 = 12kW			P6 = solutions up to 230°F	
	13.5 = 13500	8 = 208	50 = 13.5kW	-R50 = 13kW			P7 = solutions up to 300°F	
	15 = 15000	9 = 220	55 = 15kW	-R50 = 15kW				
	18 = 18000	0 = 200	64 = 18kW	-R50 = 18kW				