

# DQ15D/ T-DQ15D Instruction Manual



## TABLE OF CONTENTS

### DQ15D / T-DQ15D Digital Temperature Control

Specifications.....	1	Main Menu Summary .....	15
General Description.....	2	Sensor Type (U1) .....	15
Installation .....	2	Signal Offset (U2).....	16
Over-temperature Protection.....	3	Output Signal Offset (U3).....	16
Power and Relay Wiring .....	4	Signal Filter Setting (U4).....	16
Set Point & Features.....	4	Set Point 1 Dead Band (U5).....	16
Alarm Feature.....	5	Set Point 2 Dead Band (U6).....	17
Calibration .....	5	Power Save Set Point Dead Band (U7) .....	17
2 Wire RTD Sensor Calibration .....	6	Display Stabilizer (U8) .....	17
3 Wire RTD Calibration .....	7	Set Point Limit (L) .....	17
Resistance Signal Calibration.....	8	SP2 and U7 Disable (F1).....	18
Voltage Signal Calibration.....	9	Alarm On/Off Switch (F3).....	18
Current Input Calibration .....	10	Unit Display Enable (F4) .....	18
Frequency Signal Calibration .....	10	Temperature Units Conversion (F5) .....	18
Thermocouple Calibration .....	11	Current Output Enable (F6).....	18
4-20mA Process Output (Optional).....	12	Sensor DIP Switch Settings .....	19
Error Conditions.....	13	Electrical Noise and Interference .....	19
Error Messages.....	13	Illustration of a Typical Heater .....	
Configuration (Setup).....	14	Installation in a Process Tank.....	19



38809 Mentor Avenue • Willoughby, Ohio 44094 • Phone: 440-974-1300  
USA/CN: 800-621-1998 • Fax: 440-974-9561 • [www.processtechnology.com](http://www.processtechnology.com)

COPYRIGHT 2019 Process Technology

## DQ15D Specifications

<b>Standard Input</b>	2 wire 1000 ohm RTD TCR (alpha), 0.00385 ohm/ohm/°C
	RTD Self Heating Coefficient: 5° C/w in 0.2 m/s water; 200° C/w in 1 m/s air measurement current, 0.1 to 0.2 mA
<b>Input Range</b>	-40°F (-40°C) to 1000°F (538°C); °F or °C field selectable
<b>Set Point Range</b>	Selectable throughout the input range
<b>Sensor Break or Short Protection</b>	De-energize control output (No sensor short protection with Thermocouple sensor)
<b>Accuracy</b>	± 0.25% span, ± 1 digit
<b>Enclosure</b>	Type 12, IP54 Face suitable for panel mounting (#20 ga. through 1/4 thick panels)
<b>Display</b>	4 digit, (1/2" nominal), LED display screen
<b>Control Function</b>	ON/OFF Electromechanical Relays
<b>Control Outputs</b>	<b>SP1 Set Point</b> (reverse acting) SPDT 20A resistive@240 VAC max 1HP@240 VAC max, 1/2 HP@120VAC
	<b>SP2 Set Point</b> (direct acting) SPDT 2A resistive@240 VAC max 1/10HP@240 VAC max, 1/20 HP@120VAC
<b>ON/OFF Differential</b>	Field adjustable, 1° (F or C) to 99°
<b>Memory</b>	Nonvolatile
<b>Supply Voltage</b>	100V to 240 VAC +/-10%, 50-60 Hz, 13VA
<b>Operating Conditions</b>	<ul style="list-style-type: none"> <li>• Indoor Use Only</li> <li>• 20°F (-7°C) to 140°F (60°C)</li> <li>• Max Altitude: 3000m</li> <li>• Max Relative Humidity: 80%</li> <li>• Pollution Degree 2</li> <li>• Installation Category II</li> </ul>
<b>Input Options</b>	RTD 2 & 3-wire 100 ohm 0.00385 ohm/ohm/°C or 0.00392 ohm/ohm/°C
	Thermocouples - (types J, K, T, R)
	NIST Monograph 175, revision ITS-90 (Obsolete)
	Current 4-20mA DC
	Voltage (1-10 VDC)
	Frequency (0-200 Hz, counts/second), +/- 6 VDC p to p (up to 30VDC peak with Sw2 ON)
<b>Output Options</b>	4-20 mA DC proportional to the process (display) value. Maximum impedance 450 Ohms.

\* Equipment protected throughout by Double Insulation or Reinforced Insulation.

## General Description

The DQ15D digital temperature control is a programmable and microprocessor based device that operates two relays for temperature control.

### Features

The temperature sensor (RTD or thermocouple) sends a signal to the DQ15D to compare to a value preset by the user as a Set Point (SP). Set Points LEDs are **SP1** and **SP2** on the front panel.

- In heating mode if the sensor signal is lower than the SP1 Set Point value, DQ15D energizes the SP1 relay and its isolated contacts close.
- In cooling mode if the sensor signal is higher than the SP2 Set Point value, DQ15D energizes SP2 relay and its isolated contacts close.
- DQ15D has an optional Alarm Condition feature. After you activate this feature, when the sensor signal exceeds the Alarm Set Point, DQ15D goes into an alarm condition. In an Alarm Condition, both relays de-energize and the screen displays a flashing AAA.
- The power save, night setback feature permits the use of a second heating Set Point to conserve energy when required.

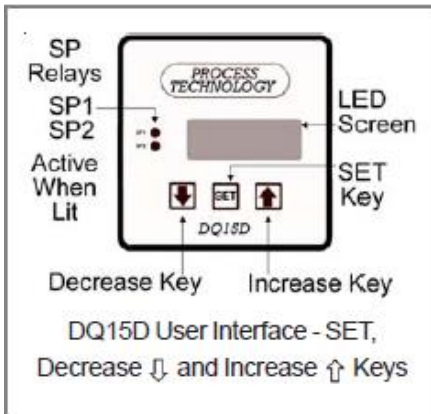

## Installation Procedure

DQ15D is for indoor use only.

- 1 Unpack and inspect DQ15D for damage upon receipt. Shipping damage claims must be made through the freight carrier.
- 2 Remove rear cover and inspect DQ15D for internal damage.

- 3 Remove the Retaining Collar. Insert a flathead screwdriver under the collar on alternating sides while sliding the collar back.
- 4 Cut a 1/4 DIN finished opening: 3.625" x 3.625" (92 mm x 92 mm) in the desired mounting panel location.
- 5 Select one or more knock-outs from the three (3) knockouts on the rear cover or enclosure side panels that offers the most convenient routing for external wiring.

**ATTENTION**

Évitez d'endommager les circuits. Enlevez le couvercle arrière avant d'enlever les débouchures avec un marteau / poinçon.

**CAUTION**

Avoid damaging circuitry. Remove rear cover before removing knockouts with a hammer/punch.

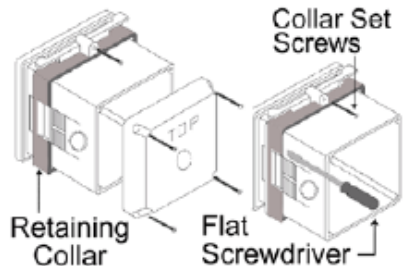
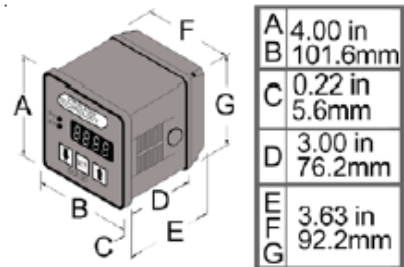

DQ15D Dimensions and Installation

## Installation Procedure (Continued)

- 6 Remove the knockouts before reattaching the rear cover or inserting the control in the panel.
- 7 Insert DQ15D through the prepared opening and slide the retaining collar over the case from the rear of the panel.
- 8 Hand tighten the collar, securely tighten the two (2) collar screws.
- 9 Install a suitable liquid-tight conduit fitting through the knock-out opening following manufacturer instructions and install field wiring.
- 10 Using the Power, Heating and Cooling Relay Wiring illustration in this chapter, install the required input and output wires. Use National Electric Code and local codes for determining wire sizing, insulation, terminations, etc.

## Wiring

This section provides wiring notes for Power Heating/Cooling relays and Overtemperature Protection.

## Overtemperature Protection

Component failure (sensors, relays, temperature controller, etc.) in a temperature controlled process can result in damage to the product, heater over temperature, and the possibility of a fire.

To safeguard against these events, install over temperature protection. This will interrupt the heater power supply in the event of low solution level.

Process Technology heaters include a thermal device (Protector 1, 2, or 3) on the heater to monitor the heater's surface temperature. When wired properly, these devices cut the power to the heater in low solution level conditions. In addition to thermal protection, Process Technology requires the use of liquid level controls to monitor the solution level and shut off the heaters prior to an overtemperature condition occurring.

Ensure you read and adhere to all Over-temperature protector installation instructions and warnings.

**AVERTISSEMENT**

La protection de surchauffe est nécessaire dans n'importe quel système où une condition fautive avec résultat d'une température haute pourrait produire un incendie ou autre condition dangereuse. L'opération sans les précautions complètes de sécurité pourrait mener à la défaillance de l'équipement, l'endommagement de la propriété, ou des blessures.

**WARNING**

Overtemperature protection is necessary in any system where a fault condition could produce a fire or any other hazardous condition. Operation without thorough safety precautions can result in equipment failure, property damage and personal injury.

## Overtemperature Protection Device with Low Level Cutoff Sample Wiring Diagram

(your wiring may differ)

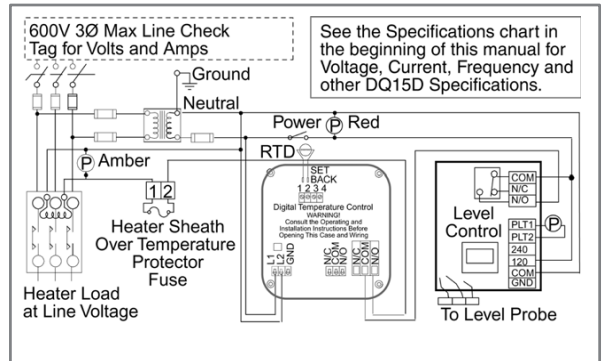

## Power and Relay Wiring Procedure

Unit is intended for a single power source. To complete the wiring procedure, you will need these tools and materials:

1. #2 Phillips head screwdriver.
2. 1/8" (x-small) straight blade screwdriver.
3. Power supply wire, 18 awg minimum.
4. Relay connection wires (see state and local electrical requirements for proper 65°C wire gauge).

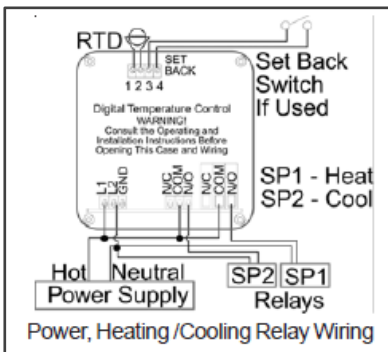

Referring to the “Power, Heating and Cooling Relay Wiring (rear view of controller)” illustration above, locate and identify terminal locations for the power supply voltage, the set point relay, and the appropriate sensor. Connect wires into their designated terminals and tighten the retaining screw which will secure the wire into place.

## Extending Wiring

The factory supplied 1000 ohm RTD sensor can be extended using standard electrical hookup wire (22 awg or larger). The effect of additional 22 awg sensor wire length on control calibration is approximately 1°F for every 65 feet.

**Note: This does not apply to THERMOCOUPLES. You MUST use specific thermocouple wire when extending the sensor wire length. Use of incorrect extension wire can cause hazardous operating conditions.**

## Relay Control Set Points

Before operation, you must program Set Points or temperature limits. When DQ15D reaches the Set Point it will energize one or both relays.

- SP1 Heat Set Point for normal Heating Mode operation. Controls SP1 relay.
- SP2 Cool Set Point for normal Cooling Mode operation. Controls SP2 relay.
- P Power Save Set Point for a second heating Set Point lower than SP1 Heat Set Point. Optional; you must enable Power Save feature. Controls SP1 relay.
- A Alarm Set Point to establish an Alarm Condition if temperature reaches the Alarm Set Point (higher than SP1 Set Point). The screen displays a flashing AAA in an Alarm Condition. Optional; you must enable Alarm feature. Controls SP1 and SP2 relays.

**Note: The units displayed, °C, °F, Hz, volts, mA or ohms are established during the setup of the controller.**

## View/Change Set Points

The screen normally displays the actual process temperature.

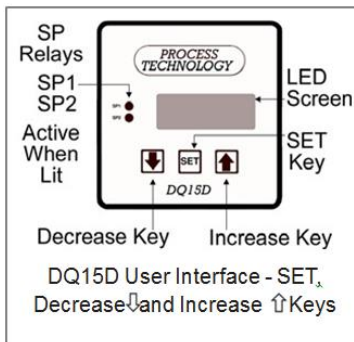

### SP1 - Heat Set Point

- 1 To view the SP1 SET POINT value, press ↓ once and release. For seven seconds, the letter H and a decimal point followed by the numeric SP1 value display. (After seven seconds the display returns to normal.)
- 2 To alter the Set Point value, press SET while the Set Point value displays (value will flash).
- 3 Once the value flashes, use ↑ or ↓ to change the value.
- 4 Within 5 seconds after changing the value, press SET again to lock the new value into memory.

**Note: If the “SET” key is not pressed within 5 seconds, the new value will be lost and the set point value will revert to its previous setting.**

**If the F1 menu feature is enabled, please see the instructions on pg. 18 for accessing SP1.**

## View/Change Set Points (Continued)

### SP2 - Cool Set Point

- 1 To view the SP2 SET POINT value, press  $\downarrow$  twice and release. For seven seconds, the letter C and a decimal point followed by the numeric SP2 value display. (After seven seconds the display returns to normal.)
- 2 To alter the Set Point value, press SET while the Set Point value still displays (value will flash).
- 3 Once the value flashes, use  $\uparrow$  or  $\downarrow$  to change the value.
- 4 Within 5 seconds after changing the value, press SET once more to lock the new value into memory.

### P – Power Save Set Point

- 1 To turn on the Power-Save feature, do one of the following tasks, never do both:
  - either press all three keys ( $\uparrow$ , SET, and  $\downarrow$ ) simultaneously, or
  - install an external switch to close contacts #3 and #4 on the rear terminal strip.When the control is operating in Power-Save mode, the display will alternately change between the process value and three dashes ---.
- 2 Return to normal SP1 operation with one of the following tasks:
  - either press all three keys ( $\uparrow$ , SET, and  $\downarrow$ ) simultaneously, or
  - switch OFF the remote switch wired to terminals #3 and #4.
- 3 To view the P SET POINT value, press  $\uparrow$  once and release. The control will display the letter P and a decimal point followed by the numeric P SET POINT value.
- 4 To change the Set Point value, press SET while the P SET POINT value displays (value will flash).
- 5 Once the value flashes, press  $\uparrow$  or  $\downarrow$  to change the value.
- 6 Press SET once to lock the new value into memory.

### Alarm Set Point

**Note: This is not a safety device.**

- 1 Enable the Alarm feature. See Configuration (Setup), F3 Alarm On/ Off Switch for instructions.
- 2 Press  $\uparrow$  twice and release. The letter A, followed by a decimal point and the Alarm Set Point value displays. (After a few seconds the screen returns to normal.)
- 3 To change the ALARM SET POINT, press SET while the alarm Set Point value still displays (value will flash).
- 4 When it flashes, use  $\uparrow$  or  $\downarrow$  to change the value, and press SET to lock the new value into memory.

## Calibration

This section includes calibration procedures for 2 & 3 wire RTDs, Resistance, Voltage, Current Input, Frequency, and Thermocouples.



### AVERTISSEMENT

**Les procédures de calibration nécessitent l'enlèvement du panneau arrière du contrôle. Ça exige aussi que le courant électrique est allumé ce qui expose le technicien à des tensions potentiellement létales. Utilisez toujours un soin extrême et portez des gants certifiés d'électricien quand le courant est allumé.**



### WARNING

**Calibration procedures require the removal of the rear cover of the control. It also requires that power is ON, exposing the technician to potentially lethal voltages. Exercise EXTREME CARE and wear tested electrician's gloves whenever power is on.**

## 2 Wire RTD Sensor Calibration

RTD devices are precision resistors whose resistance value varies with temperature. DQ15D measures RTD resistance and compares that value with a standard set of values stored in memory. You can restore, update or verify that this standard set of values is correct.

### Equipment needed

- Two precision resistors (tolerance +/- 0.1% or better) with a fixed value equal to the RTD nominal value (i.e. 1000 ohms).
- A suitable jumper cable to facilitate changing input resistance.

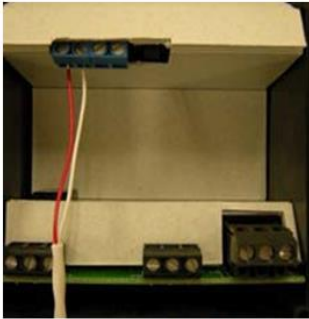

Before Beginning RTD Calibration

### Calibration Procedure

- 1 Turn OFF all power.
- 2 Remove rear cover.
- 3 Ensure the 2 wire, 1000 ohm RTD sensor is connected across terminals #1 AND #2 of the terminal block before beginning.
- 4 Remove RTD sensor.
- 5 Install the precision resistors in place of the RTD, as shown.

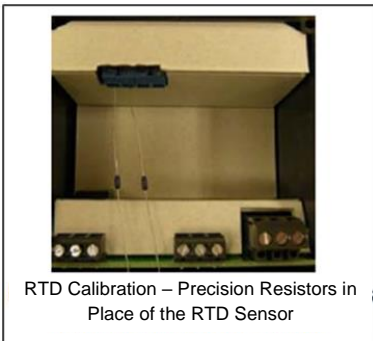

RTD Calibration – Precision Resistors in Place of the RTD Sensor

- 6 Install the jumper cable between the loose end of

one resistor and the fixed end of the other resistor to establish an input value of a single resistor (i.e. 1000 ohms), as shown. Install the jumper cable between the loose end of one resistor and the fixed end of the other resistor to establish an input value of a single resistor (i.e. 1000 ohms), as shown.

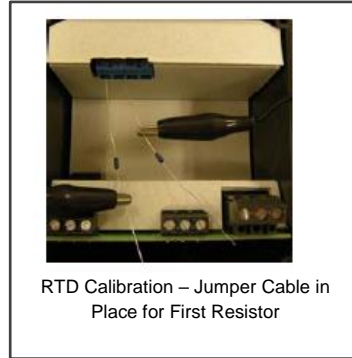

RTD Calibration – Jumper Cable in Place for First Resistor

- 7 Carefully restore power to the control, taking precautions not to make contact with any exposed voltage sources.
- 8 Press and hold  $\uparrow$  and  $\downarrow$  simultaneously for approximately 6 seconds. The display will indicate AC.0. while the 0 is flashing, use  $\uparrow$  to change this to 22. Press SET. The control screen displays CAL1.
- 9 Press and hold SET for 1 second. HoLD displays on the screen. Wait for CAL2 to display.
- 10 Proceed with caution to avoid SHOCK hazard. Remove and relocate one end of the jumper cable to the loose end of the second precision resistor for the second resistance value (i.e. 2000 ohms), as shown.



RTD Calibration – Jumper Cable in Place for Second Resistor

## 2 Wire RTD Sensor Calibration (Continued)

- 11 Press and hold SET for 1 second. The screen displays HoLd . WAIT for the display to reset. After resetting, the connected precision resistors' approximate temperature value should display (i.e. 511° F or 266° C).
- 12 Turn OFF power and remove the precision resistors. Reinstall the RTD sensor and the rear cover of the controller. Return the calibrated controller to service.

## 3 Wire RTD Sensor Calibration

Optional input boards, Item # 5447 or 5416 needed. This board will accept 2 wire RTDs as well. RTD devices are precision resistors whose resistance value varies with temperature. The connection of a third wire eliminates the natural resistance of the lead wires to improve sensor accuracy. The DQ15D control measures the RTD resistance (and the third wire resistance) and compares that measurement with a standard set of values stored in the memory. You can restore, update or verify that the standard set of values is correct.

**Note: For a 1000 ohm sensor, the DIP switches should be OFF, OFF, OFF. For 100 ohm, ensure the DIP switches are ON, OFF, OFF. See Dip Switch Settings in Configuration (Setup).**

### Equipment needed

- Two precision resistors (tolerance +/- 0.1% or better) with a fixed value equal to the RTD nominal value (i.e. 1000 or 100 ohms).
- A suitable jumper cable to facilitate changing input resistance.
- A short piece of jumper wire (simulates third wire).



**AVERTISSEMENT**

Les procédures de calibration nécessitent l'enlèvement du panneau arrière du contrôle. Ça exige aussi que le courant électrique est allumé ce qui expose le technicien à des tensions potentiellement létales. Utilisez toujours un soin extrême et portez des gants certifiés d'électricien quand le courant est allumé.



**WARNING**

Calibration procedures require the removal of the rear cover of the control. It also requires that power is ON, exposing the technician to potentially lethal voltages. Exercise **EXTREME CARE** and wear tested electrician's gloves whenever power is on.

### Calibration Procedure

- 1 Turn OFF all power.
- 2 Remove rear cover.
- 3 Remove RTD sensor.
- 4 Install the short piece of jumper wire from terminal #1 to #3.
- 5 Install the precision resistors in place of the RTD sensor, as shown in terminals #2 and #3.

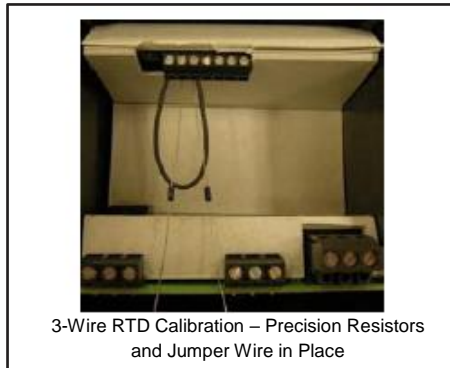

3-Wire RTD Calibration – Precision Resistors and Jumper Wire in Place

- 6 Install the jumper cable between the loose end of one of the resistors and the fixed end of the other resistor to establish an input value of a single resistor (i.e. 1000 ohms or 100 ohms), as shown.
- 7 Carefully restore power to the controller. Do not come in contact with any exposed voltage.



### 3 Wire RTD Sensor Calibration (Continued)

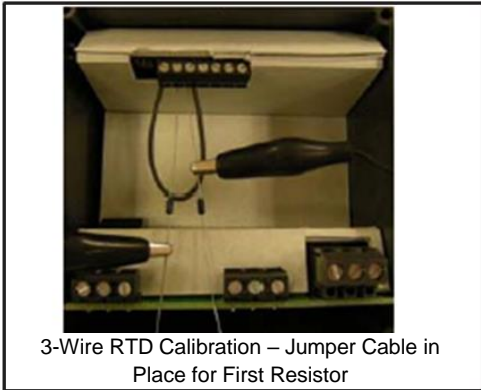

- 8 Press  $\uparrow$  and  $\downarrow$  simultaneously and hold for approximately 6 sec. The screen displays AC.0. While the 0 is flashing, use  $\uparrow$  to change this to 22. Press SET. CAL1 displays.
- 9 Press and hold SET for one sec. The screen displays Hold. Wait for the message to change to CAL2.
- 10 Proceed with CAUTION to avoid SHOCK hazard. Remove and relocate one end of the jumper cable to the loose end of the second precision resistor for the second resistance value (i.e. 2000 ohms or 200 ohms), as shown.

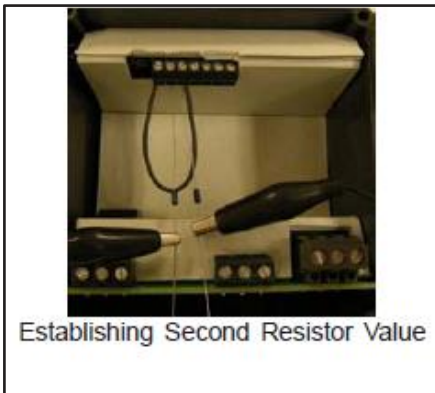

- 11 Press and hold SET for one second. The screen displays Hold. Wait for the display to reset. After it resets, the approximate temperature value for the connected precision resistors should display (i.e. 511° F or 266°C).

- 12 Turn OFF power to the controller and remove the precision resistors. Retain for future use. Reinstall the RTD sensor and rear cover of controller. Return the calibrated controller to service.

### Resistance Signal Calibration

This section describes how to configure and calibrate DQ15D to measure pure resistance.

#### Equipment needed

Refer to the calibration procedure for the 2 wire RTD sensor for equipment needed.

#### Calibration Procedure

- 1 From the setting configuration mode, set the U1 sensor type parameter to 12. See **Configuration (Setup)**.
- 2 Follow the Calibration Procedure for a 2 wire RTD sensor. DQ15D will then measure pure resistance from 0-1000 ohms.

## Voltage Signal Calibration

The DQ15D control measures DC voltage and compares that measurement with a standard set of values in the control memory.

### AVERTISSEMENT

Les procédures de calibration nécessitent l'enlèvement du panneau arrière du contrôle. Ça exige aussi que le courant électrique est allumé ce qui expose le technicien à des tensions potentiellement létales. Utilisez toujours un soin extrême et portez des gants certifiés d'électricien quand le courant est allumé.

### WARNING

Calibration procedures require the removal of the rear cover of the control. It also requires that power is ON, exposing the technician to potentially lethal voltages. Exercise **EXTREME CARE** and wear tested electrician's gloves whenever power is on.

### Equipment Needed

Optional input boards, Item # 5447 or 5416 needed.

### Verify Standard Values

To restore, update or merely verify that this standard set of values is correct, do the following:

- Make sure that the DIP switch settings are OFF, ON, OFF. See Dip Switch Settings in **Configuration (Setup)**.
- The voltage signal must be connected across terminals #1 and #2 of the Adder Board (Item # 5416 or 5447). Terminal #2 is common (negative), and terminal #1 is the signal connection (positive).
- Always observe polarity.

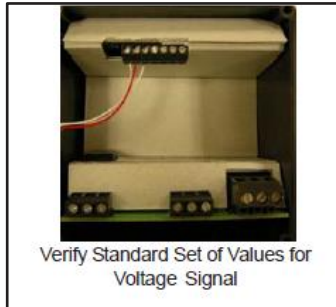

### Calibration Procedure

- 1 Turn OFF all power.
- 2 Remove rear cover.
- 3 Remove voltage input wiring.
- 4 Install a voltage calibrator or power supply to terminals 1 and 2.

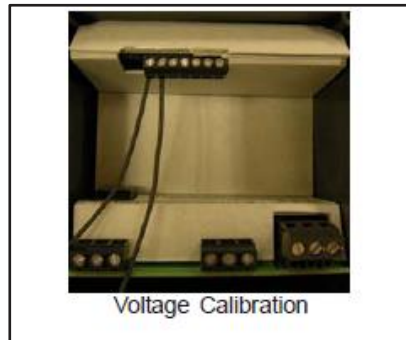

- 5 CAREFULLY restore power to the controller, ensuring that you do not come in contact with any exposed voltage.
- 6 Press  $\uparrow$  and  $\downarrow$  simultaneously and hold for approximately 6 seconds. The screen displays AC.0. While the 0 is flashing, use  $\uparrow$  to change this to 22. Press SET. The control screen displays CAL1.
- 7 Adjust power supply to 1.0V.
- 8 Press and hold SET for one second. The screen displays Hold. Wait for display to change to CAL2.
- 9 Adjust calibrator to 10.0V.
- 10 Press and hold SET for one second. The screen displays Hold. Wait for display to reset and display 10.0.
- 11 Turn OFF power to the control and remove the calibrator. Reinstall the voltage input and the rear cover of the control. Return the calibrated controller to service.

## Current Input Calibration

The DQ15D control measures the DC current and compares that measurement with a standard set of values in the control memory.

### Verify Standard Values

To restore, update or merely verify that this standard set of values is correct, do the following:

- Make sure that the DIP switch settings are OFF, OFF, ON. See Dip Switch Settings in **Configuration (Setup)**.
- Terminal 1 is positive, terminal 2 is negative.

### Equipment Needed

- Optional input boards, item # 5447 or 5416
- A precision, NIST traceable, 0-20 mA DC current calibrator OR a precision, NIST traceable, digital ammeter or DMM
- a regulated linear DC power supply with an adjustable 0-10 volt or better output and,
- a 400 ohm, 0.1% or better tolerance, precision resistor.



## AVERTISSEMENT

Les procédures de calibration nécessitent l'enlèvement du panneau arrière du contrôle. Ça exige aussi que le courant électrique est allumé ce qui expose le technicien à des tensions potentiellement létales. Utilisez toujours un soin extrême et portez des gants certifiés d'électricien quand le courant est allumé.



## WARNING

Calibration procedures require the removal of the rear cover of the control. It also requires that power is ON, exposing the technician to potentially lethal voltages. Exercise **EXTREME CARE** and wear tested electrician's gloves whenever power is on.

## Calibration Procedure

- 1 Turn OFF all power.
- 2 Remove rear cover.
- 3 Remove input leads.
- 4 Install the 0-20 mA DC calibrator or the power supply, resistor and ammeter in series with terminal #1 and #2.
- 5 CAREFULLY restore power to the controller, ensuring that you do not come in contact with any exposed voltage.
- 6 Press  $\uparrow$  and  $\downarrow$  simultaneously and hold for approximately 6 seconds. The screen displays AC.0. while the 0 is flashing, use  $\uparrow$  to change this to 22. Press SET. The screen then displays CAL1.
- 7 Adjust the calibrator or power supply to 5.0 mA.
- 8 Press and hold SET for one second. The screen displays Hold. Wait for it to change to CAL2.
- 9 Adjust power supply to 20.0 mA.
- 10 Press and hold SET for one second. The screen displays Hold. Wait for display to reset and display 20.0.
- 11 Turn OFF power to the control and remove the power supply.
- 12 Reinstall the voltage input and the DQ15D rear cover and return the calibrated controller to service.

## Frequency Signal (Pulse Train) Calibration

The DQ15D measures frequency and compares it with a standard set of values derived from the microprocessor oscillator.

### Equipment needed

- Optional input boards, item # 5447 or 5416. Check that the DIP switches are set to OFF, OFF, OFF. See Dip Switch Settings in See **Configuration (Setup)**.

### Calibration Procedure

Since this is a dedicated frequency, no field calibration is possible.

## Thermocouple Calibration

Installation requires configuration for the specific thermocouple used.

- The two wire thermocouple is polarized, therefore it is necessary to connect the negative lead wire of the thermocouple to the #1 terminal and the positive lead wire to the #2 terminal to maintain proper polarity for the Item # 5418 sensor board.
- Connect the negative lead wire to terminal #2 and the positive to terminal #3 for the Item # 5419 Sensor board.

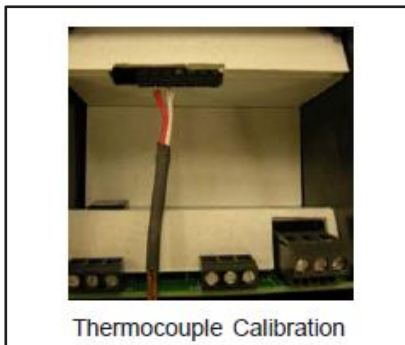

### Equipment needed

- Optional thermocouple sensor board needed (Item # 5418 or 5419).
- A precise, NIST traceable, thermocouple calibrator with suitable extension leads to match the thermocouple type used.

## AVERTISSEMENT

Les procédures de calibration nécessitent l'enlèvement du panneau arrière du contrôle.

## WARNING

Calibration procedures require the removal of the rear cover of the control. It also requires that power is ON, exposing the technician to potentially lethal voltages. Exercise **EXTREME CARE** and wear tested electrician's gloves whenever power is on.

## Calibration Procedure

- 1 Turn OFF all power.
- 2 Remove rear cover.
- 3 Remove T/C sensor.
- 4 Install the thermocouple calibrator to terminal #1 and #2 on Item # 5418 board, or terminal #2 and #3 on 5419 sensor board.
- 5 CAREFULLY restore power to the controller, ensuring you do not come in contact with any exposed voltage.
- 6 Press  $\uparrow$  and  $\downarrow$  keys simultaneously and hold for approximately 6 seconds. The display will indicate AC.0.  
While the 0 is flashing, use  $\uparrow$  to change this to 22. Press SET. The control screen displays CAL1.
- 7 Adjust the thermocouple calibrator to 0.0° C (32.0° F).
- 8 Press and hold SET for one second. The screen displays Hold. Wait for display to change to CAL2.
- 9 Adjust the thermocouple calibrator to 250.0° C (482.0° F).
- 10 Press and hold SET for one second. The screen displays Hold. Wait for the display to reset and display 250.0° C (482.0° F).
- 11 Turn OFF power to the control and remove the thermocouple calibrator. Reinstall the thermocouple sensor and the rear cover of the control. Return the calibrated controller to service.

## 4-20 mA Output (“-M” Option)

The DQ15D is available with an optional 4-20 mA output signal proportional to the measured (displayed) temperature. This option is useful for source transmitting the measured temperature to a current loop-sensing device such as a PLC, remote intelligent display or chart recorder. Use Terminals #2 and #3 for 2 wire 1000 ohm RTD.

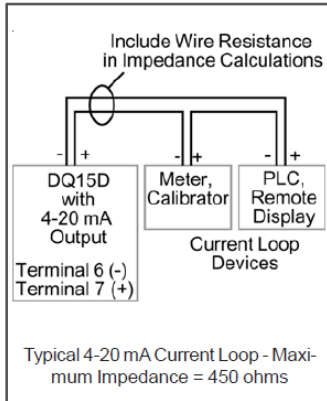

Factory calibration is verified using an intelligent NIST traceable 4 digit DMM, a NIST traceable sensor calibrator, and an intelligent display. The factory range setting is 0-500° F vs. 4-20 mA. Custom ranges can be accommodated if specified at time of order. Field calibration can use a similar arrangement or a 4-20 mA calibrator for verification. Since calibration is an involved operation, it is suggested that it be performed only after determining that the measured values differ from factory settings, or if the output range is to be altered. Use Terminals #2 and #3 for 2 wire 1000ohm RTD.

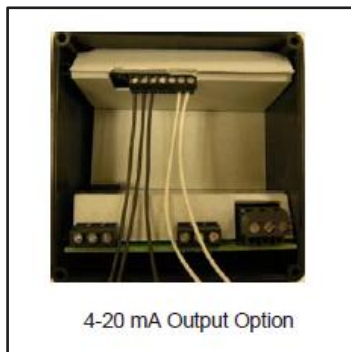

### Equipment needed:

- Item #5416 or 5419 board.
- An NIS T traceable sensor simulator (calibrator), a precision 20 mA or higher calibrator/tester, or a precision DMM for verification.

## AVERTISSEMENT

Les procédures de calibration nécessitent l'enlèvement du panneau arrière du contrôle. Ça exige aussi que le courant électrique est allumé ce qui expose le technicien à des tensions potentiellement létales. Utilisez toujours un soin extrême et portez des gants certifiés d'électricien quand le courant est allumé.

## WARNING

Calibration procedures require the removal of the rear cover of the control. It also requires that power is ON, exposing the technician to potentially lethal voltages. Exercise **EXTREME CARE** and wear tested electrician's gloves whenever power is on.

### Calibration Procedure:

- 1 Turn OFF all power.
- 2 Remove rear cover.
- 3 Remove sensor leads.
- 4 Install appropriate sensor calibrator, i.e. resistors or thermocouple simulator.
- 5 Remove ONE lead of the 4-20 mA output wire and install the DMM or tester in series with the external loop and this terminal. OBSERVE POLARITY.
- 6 Restore power to control.
- 7 Verify basic instrument sensor input accuracy by simulating various sensor inputs and observing the display values. If out of tolerance, perform appropriate sensor calibration before proceeding.
- 8 Simultaneously press and hold  $\downarrow$  and  $\uparrow$  for approximately 6 sec. The screen displays AC.0. While the 0 is flashing, use  $\uparrow$  to enter 33. The screen changes to display L followed by the current lower process limit, i.e. 0°, -20°, 0V, etc.
- 9 Use  $\uparrow$  or  $\downarrow$  to alter the lower display value. Press SET to store the new value. The display will then read hexadecimal 2AAA or 4.0mA, verify that this is the value displayed on your 4-20 mA calibrator/tester or DMM.

## 4-20 mA Output (Continued)

- 10 Press  $\uparrow$  or  $\downarrow$  to adjust the lower current value. Press SET to retain the value. The screen displays U followed by the current upper display value limit, (i.e. 500°, 10 volt)
- 11 Use  $\uparrow$  or  $\downarrow$  to alter the upper display value. Press SET to retain the value. The display will then read hexadecimal D555 or 20.0 mA.
- 12 Verify the value by observing the value on your 4-20 mA calibrator/tester or DMM.
- 13 Adjust the upper current output value by pressing  $\uparrow$  or  $\downarrow$ . Press SET to retain the value. The current sensor input value then displays and the 4-20 mA output will reflect your new or confirmed settings.
- 14 Turn OFF all power.
- 15 Disconnect calibration equipment.
- 16 Reconnect 4-20 mA lead and sensor leads.
- 17 Reinstall rear cover.

## Error Conditions

Sensor values that are out of range will generate an error display. The temperature range is as follows:

Celsius: <-40° C or >+538° C

Fahrenheit: <-40° F or >+1000° F

### Calibration Error Messages

If calibration or setup information stored in the memory becomes corrupt or erased, DQ15D switches to its default calibration and setup settings. A flashing letter c displays on the left side when DQ15D switches to default settings. The size and position of the letter c will define the exact nature of the problem.

- c A small c in the upper left-hand corner indicates the control is relying on default (factory set) calibration values. This happens when the control is new and has not yet been calibrated (setup).
- c A small c in the lower left hand corner indicates the control is relying on default configuration values. This is a rare condition, but may occur if the control has been calibrated for use with a two-wire RTD sensor but the configuration parameters have not been changed from their default values. Changing any of the configuration or Set Point variables will turn off this indication.

C A large C on the left side of the display indicates default values are being used for the configuration and the calibration. This can occur in a new control that has never been calibrated or configured, or if the memory has been erased.

### RTD Error Messages

If the screen displays one of the following messages, the control relay de-energized due to an RTD condition.

HHH A thermocouple or RTD sensor is improperly connected, or the control read an open circuit.

UUU The RTD sensor shorted.

**Note: This does not apply to THERMOCOUPLES. A thermocouple short causes a new junction/measurement point to be created. This will lead to false readings and dangerous operating conditions. Shorted thermocouples will not result in an error condition. Instead, incorrect readings will be displayed.**

## Configuration (Set-up)

- 1 To configure the DQ15D, press  $\uparrow$  and  $\downarrow$  simultaneously and hold for approximately 6 seconds. The screen displays AC.0.
- 2 While the 0 is flashing, use  $\uparrow$  to change this to 11. Press **SET**. The control will be in the configuration mode. While in this mode, the screen displays the values of various configuration settings. The first setting to display is the U1 setting. See setting summary. By using  $\uparrow$  and  $\downarrow$  keys, it is possible to scroll through the list of settings to those needing modification.

### Adjust Configuration Setting

- 1 To adjust a setting while in the Configuration Mode, use  $\uparrow$  and  $\downarrow$  to bring the particular setting into the view on the screen.
- 2 Press **SET** to change the value of the setting. Once **SET** has been released, the display will flash.
- 3 Use  $\uparrow$  and  $\downarrow$  to scroll through the options for the selected setting.
- 4 After the option has been determined, press **SET** once more to lock the new value into memory.
- 5 After completing all changes to the configuration of the control, the new configuration must be saved. To save the new value, press  $\uparrow$  and  $\downarrow$  simultaneously. This will cause the control to store the new values internally and then reset the unit.

**Note:** Switching off power to the unit before saving the new configuration will cause all changes to be lost.

## Sensor DIP Switch

When using the sensor 5416 or 5447 boards, an on-board DIP switch must also be configured.

Sw1	Sw2	Sw3	Type
OFF	OFF	OFF	1000 ohm RTD
ON	OFF	OFF	100 ohm RTD
OFF	ON	OFF	voltage
OFF	OFF	ON	current
OFF	OFF	OFF	frequency

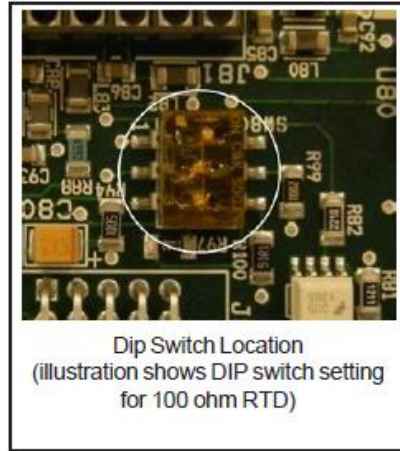

## Main Menu Summary

<u>Label</u>	<u>Settings</u>	<u>Description</u>
U1	Sensor Type	Used to select the type of sensor
U2	Signal Offset	Offset value from -9 to +9 applied to reading
U3	Output Signal Offset	Adjusts 4-20 mA output from -9 to +9
U4	Signal Filter	Adjustable running average filter on input signals
U5	Set Point Dead Band (SP1)	Value from 1 to 99 applied to SP1
U6	Set Point Dead Band (SP2)	Value from 1 to 99 applied to SP2
U7	Power Save	Set Point value from 1 to 99, power save mode
U8	Display Stabilizer	Reduces display instability when used in conjunction with U4
L	Set Point Limit	High set point limit for SP1, SP2, power save and alarm
F1	SP2 and U7 Disable	Modifies DQ15D controller to single set point
F2	Heat/Cool Switch	N/A
F3	Alarm Enable	Toggle flag to enable the "alarm set point" feature
F4	Unit Display Enable	Toggle flag enabling temperature units to be displayed
F5	Temperature Unit	Toggle flag to select °F or °C
F6	Current Output Enable	Enable 4-20 mA output

### U1, Sensor Type

This setting tells the DQ15D control what type of sensor it is using.

<u>Value</u>	<u>Board</u>	<u>Sensor Type</u>	<u>Sensor Description</u>
1	5414 or 5416	2-wire RTD	Platinum RTD, TCR 0.00385 ohm/ohm/°C
2	5414 or 5416	2-wire RTD	Platinum RTD, TCR 0.00392 ohm/ohm/°C
3	5447* or 5416	3-wireV RTD	Platinum RTD, TCR 0.00385 ohm/ohm/°C
4	5447* or 5416	3-wire RTD	Platinum RTD, TCR 0.00392 ohm/ohm/°C
5	5418* or 5419*	Thermocouple	J-Type Iron-Constantan NIST Monograph 175 REV ITS-90
6	5418* or 5419*	Thermocouple	K-Type Chromel-Alumel NIST Monograph 175 REV ITS-90
7	5418* or 5419*	Thermocouple	T-Type Copper-Constantan NIST Monograph 175 REV ITS-90
8	5418* or 5419*	Thermocouple	R-Type Platinum, 13% Rhodium-Platinum NIST Monograph 175 REV ITS-90
9	5447* or 5416	Voltage	Potential signal (1.0 to 10.0 V)
10	5447* or 5416	Current	Current signal (4.00 to 20.00 mA)
11	5447* or 5416	Frequency	Pulse train frequency (0 to 200 Hz, counts per second)
12	5447* or 5416	Resistance	Pure resistance signal (0 to 1000 ohms)

*Note: The 5447 sensor board will also accept 2 wire RTDs. The default sensor type setting is "1" (1000 ohm 2 wire RTD). When using the 5447 sensor board, an "on-board" DIP switch must also be configured, see page 14.*

***\*Input boards 5418, 5419 and 5447 are no longer available.***



## U2, Signal Offset

This setting, which may be any number from -9 to +9, represents an offset value which is applied to the signal received from the sensor. The units (°C, °F, ohms, etc.) will be dictated by the type of sensor selected in “U1” settings.

<b>Temperature Sensor</b>	<b>Number represents degrees Celsius or Fahrenheit as determined by the “F5” setting</b>
<b>Voltage Sensor</b>	<b>Number represents tenths of a volt (0.1 VDC)</b>
<b>Current Sensor</b>	<b>Number represents hundredths of milliamps (0.01 mA)</b>
<b>Resistance Signal Devices</b>	<b>Number represents ohms.</b>
<b>Frequency Signal Devices</b>	<b>This setting will have no effect.</b>

## U3, Output Signal Offset

U3 adjusts the optional 4-20 mA process value output. It can be any number from -9 to +9 and is added to the signal level to cause the value to be rounded in an intelligent receiving device. This does not affect display value.

This function requires either the optional 5416 or 5419 sensor boards.

**The default and minimum for the parameter is one (1).**

**Temperature Sensor:** Number represents degrees C or F as determined by F5 setting

**Voltage Sensor:** Number represents tenths of a Volt (0.1 VDC)

**Current Sensor:** Number represents hundredths of milliamps (0.01 mA)

**Resistance Signal Devices:** Number represents ohms.

**Frequency Signal Devices:** Setting represents hertz (counts/second).

## U4, Signal Filter

This setting, which may be any number from 1 to 64, represents the number of samples taken from the sensor and maintained in memory. These samples are then averaged to provide an active filter of the signal. Using a small value for this setting will cause the DQ15D control to respond more quickly to sudden changes in the sensor signal level, but this also causes the unit to be more susceptible to EMI/RFI noise. As this value is increased, the susceptibility to inference is reduced.

**The default value for this setting is four (4).**

**Note: When sensing temperature with a 100 ohm RTD (2 or 3 wire), set this value to twenty (20) to reduce control error.**

When sensing frequency signal, this setting establishes the time period for the controller to wait for a pulse signal. Use two (2) for this value when measuring frequency. This causes the control to measure frequencies as low as 1 hertz while updating the display once every two seconds.

## U5, SP1 Dead Band

This setting, which may be any number from 1 to +99 represents a dead band that only applies to the SP1 SET POINT. This is the heat Set Point.

**The default and minimum for the setting is one (1).**

**Temperature Sensor:** Number represents degrees C or F as determined by F5 setting

**Voltage Sensor:** Number represents tenths of a Volt (0.1 VDC)

**Current Sensor:** Number represents hundredths of milliamps (0.01 mA)

**Resistance Signal Devices:** Number represents ohms.

**Frequency Signal Devices:** Setting represents hertz (counts/second)

This bandwidth applies to the low side of the SP1 SET POINT. If the U5 setting is set at 5° F and the SP1 SET POINT is set at 115° F, then the Set Point relay is de-energized when the (displayed) temperature reaches 115° F and it is reenergized when the temperature falls to 110° F.

## U6, SP2 Dead Band

This setting, which may be any number from 1 to +99 represents a dead band that only applies to the SP2 SET POINT. This is the cool Set Point.

**The default and minimum for the setting is one (1).**

**Temperature Sensor:** Number represents degrees C or F as determined by F5 setting

**Voltage Sensor:** Number represents tenths of a Volt (0.1 VDC)

**Current Sensor:** Number represents hundredths of milliamps (0.01 mA)

**Resistance Signal Devices:** Number represents ohms.

**Frequency Signal Devices:** Setting represents hertz (counts/second)

This bandwidth applies to the high side of the SP2 SET POINT. If the U6 setting is set at 5° F and the SP2 SET POINT is set at 115° F, then the Set Point relay is de-energized when the (displayed) temperature reaches 115° F and will remain de-energized until the temperature increases to 120° F.

## U7, Power Save Set Point Dead Band

This setting, which may be any number from 1 to +99, represents a dead band that only applies to the Power Save SET POINT.

**Temperature Sensor:** Number represents degrees C or F as determined by F5 setting

**Voltage Sensor:** Number represents tenths of a Volt (0.1 VDC)

**Current Sensor:** Number represents hundredths of milliamps (0.01 mA)

**Resistance Signal Devices:** Number represents ohms.

**Frequency Signal Devices:** Setting represents hertz (counts/second)

If the Power Save SET POINT dead band setting is set at 10° F and the Power Save SET POINT is 75°F, the SP1 relay de-energizes when the temperature reaches 75° F and reenergizes when the temperature falls to 65° F.

## U8, Display Stabilizer

If the display value changes by a digit or two in a steady state condition, this setting can be altered in conjunction with the U4 setting to reduce the display instability. Lower values cause maximum suppression. Larger values provide greater accuracy.

**The default value for the U8, Display Stabilizer setting is ten (10).**

## L, Set Point Limit

This setting, which may be any number between -99 and +999, is the maximum limit for all SET POINTS except the ALARM SET POINT. This will prevent accidental setting of a Set Point, which could be too high or low (depending upon the application).

**Temperature Sensor:** Number represents degrees C or F as determined by F5 setting

**Voltage Sensor:** Number represents tenths of a Volt (0.1 VDC)

**Current Sensor:** Number represents hundredths of milliamps (0.01 mA)

**Resistance Signal Devices:** Number represents ohms.

**Frequency Signal Devices:** Setting represents hertz (counts/second)

**The default value for this setting is +999.**

### F1, SP2 and U7 Disable

This setting may be either a one (1) or a zero (0), and controls the behavior of the DQ15D by making it perform like the single Set Point PROCESS TECHNOLOGY model DE control. When this setting is set to one (1), it is **ON**. The SP2 Set Point and the U7 Power Save Set Point are both disabled and will not work.

**NOTE:** To access the SP1 Set Point with this feature enabled, the  $\downarrow$  key and **SET** key must be pressed simultaneously until the display flashes. You can then proceed as described on page 4, step 2, under Change/View Set Points, to increase or decrease to the desired set point.

### F2, Heating or Cooling Switch

Not available.

### F3, Alarm On/Off Switch

This setting may be a zero (0) or a one (1). When set to zero, the alarm set point is turned off. When set to one, alarm set point is turned on.

**Note: The default value for this setting is zero (0).**

### F4, Unit Display Enable Flag

This setting may be set to a zero (0) or a one (1). When set to one (1), the DQ15D will display either a "C" or an "F", separated by a decimal point. This indicates that either Celsius or Fahrenheit is being displayed. If the temperature being measured is greater than +999 degrees, the units are not shown because the display is limited to four positions.

### F5, Temperature Units Conversion

This setting may be set to a zero (0) or a one (1). When set to a zero (0), the temperature is displayed in degrees Fahrenheit. When set to a one (1), the temperature is displayed in degrees Celsius.

Conversion from F to C does **NOT** change set point or alarm upper limit values. These must be changed manually.

**Note: The default setting is zero (0).**

### F6, Current Output Enable Flag

This setting can be either zero (0), which is OFF, or one (1), which is ON. When ON, it enables the optional current adder board on the DQ15D. See **4-20 mA Output Option** for details on the current output signal.

If the DQ15D is equipped with the optional 4-10 mA output feature, then setting F6 to one (1) turns ON this feature. F6 must be ON before any calibration can be performed.

**The default setting is zero (0).** Only active when using the optional 5416 board.

## Sensor DIP Switch Settings

When using the sensor boards 5416 or 5447, an "on-board" DIP switch must also be configured. The DIP switch settings are as follows:

### Sensor DIP Switch:

#### Selections

Sw1	Sw2	Sw3	Type
OFF	OFF	OFF	1000 ohm RTD
ON	OFF	OFF	100 ohm RTD
OFF	ON	OFF	voltage
OFF	OFF	ON	current
OFF	OFF	OFF	frequency

(Illustration shows DIP switch setting for 100 ohm RTD.)

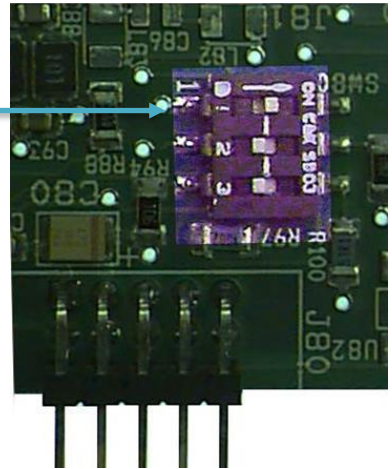

## Electrical Noise and Interference

Process Technology electronic controls are engineered, tested and manufactured to conform to Europe's CE levels of electrical noise and interference found in typical industrial installations. It is always possible for electrical noise and interference to exceed the level of designed-in protection. This can happen, for example, if arc or spot-welding equipment is close to the control or if they share a common power line. It can occur if flame ignition systems or electrostatic precipitators are in the vicinity of the control. A more common source of interference occurs when the control is switching inductive loads such as contactor coils, solenoids or motors. The collapse of the magnetic field when loads such as these are switched off can create an electrical "spike" that can cause a malfunction of the microprocessor used in the control. Even if the control doing the switching is unaffected, a nearby control may be affected. To eliminate or minimize this problem, transient suppressors or "snubbers" can be employed across the inductive load.

### Illustration of a Typical Heater Installation in a Process Tank

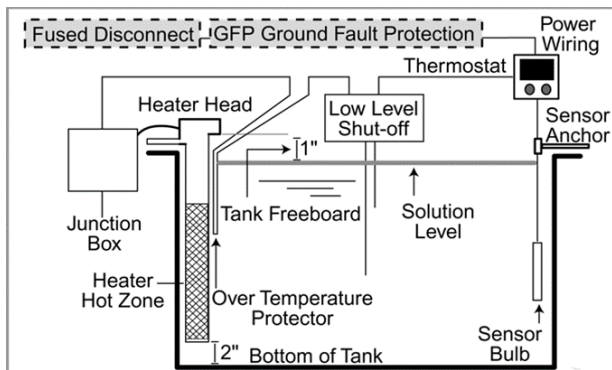

**CONSULT INSTALLATION AND MAINTENANCE INFORMATION FOR SPECIFIC INSTRUCTIONS**