



# SINGLE METAL OVER THE SIDE HEATER

Durable, efficient metal heater. Available in Steel, 304 Stainless Steel, 316 Stainless Steel, and Titanium.



## FEATURES

For use in most aqueous alkaline solutions, plating and phosphate tanks. Check solution recommendation chart with your chemical supplier for proper sheath material selection.

Heavy wall metal sheaths available in: steel, 304 stainless steel, 316 stainless steel, titanium.

Watt densities up to 35 watts per square inch (5.4 w/cm<sup>2</sup>) ensure long service life.

Vapor-resistant, flame retardant polypropylene terminal enclosure with 3 ft (.9m) flexible PVC liquid tight conduit.

Temperature and level controls sized to match the heater.

Lower watt densities for highly viscous solutions.

NOTE: Intended for vertical installation only.

P, F, S, and T SERIES, METAL HEATERS								
WATTS	VOLTS	HOT ZONE	OVERALL LENGTH	STEEL	304 SS	316 SS	TITANIUM	SHIP WGT.
		In./(mm)	In./(mm)					Lbs./(kg)
1000	120	6	11	P1111-**	F1111-**	S1111-**	T1111-**	8
	240	(152)	(279)	P1211-**	F1211-**	S1211-**	T1211-**	(3.6)
2000	240	10	17	P2217-**	F2217-**	S2217-**	T2217-**	10
	480	(254)	(432)	P2417-**	F2417-**	S2417-**	T2417-**	(4.5)
3000	240	16	23	P3223-**	F3223-**	S3223-**	T3223-**	12
	480	(406)	(584)	P3423-**	F3423-**	S3423-**	T3423-**	(5.4)
4000	240	20	29	P4229-**	F4229-**	S4229-**	T4229-**	13
	480	(508)	(737)	P4429-**	F4429-**	S4429-**	T4429-**	(5.9)
5000	240	25	35	P5235-**	F5235-**	S5235-**	T5235-**	16
	480	(635)	(889)	P5435-**	F5435-**	S5435-**	T5435-**	(7.3)
6000	240	30	40	P6240-**	F6240-**	S6240-**	T6240-**	18
	480	(762)	(1016)	P6440-**	F6440-**	S6440-**	T6440-**	(8.2)
8000	240	37	47	P8247-**	F8247-**	S8247-**	T8247-**	23
	480	(940)	(1194)	P8447-**	F8447-**	S8447-**	T8447-**	(10.4)
9000	240	44	54	P9254-**	F9254-**	S9254-**	T9254-**	24
	480	(1118)	(1372)	P9454-**	F9454-**	S9454-**	T9454-**	(10.9)
10000	240	49	59	P10259-**	F10259-**	S10259-**	T10259-**	25
	480	(1245)	(1499)	P10459-**	F10459-**	S10459-**	T10459-**	(11.3)
12000	240	58	68	P12268-**	F12268-**	S12268-**	T12268-**	29
	480	(1473)	(1727)	P12468-**	F12468-**	S12468-**	T12468-**	(13.2)

# Metal Over the Side Heater

## SPECIFICATIONS

Wattages	1,000 Watts to 12,000 Watts
Voltages	120 volts to 480 volts
Options	Special configurations & lengths Longer wire and conduit lengths All metal welded junction box
Safety Features	Grounded construction Thermal protector built in. Replaceable PI protector standard for solutions See chart below for options

## DIMENSIONS

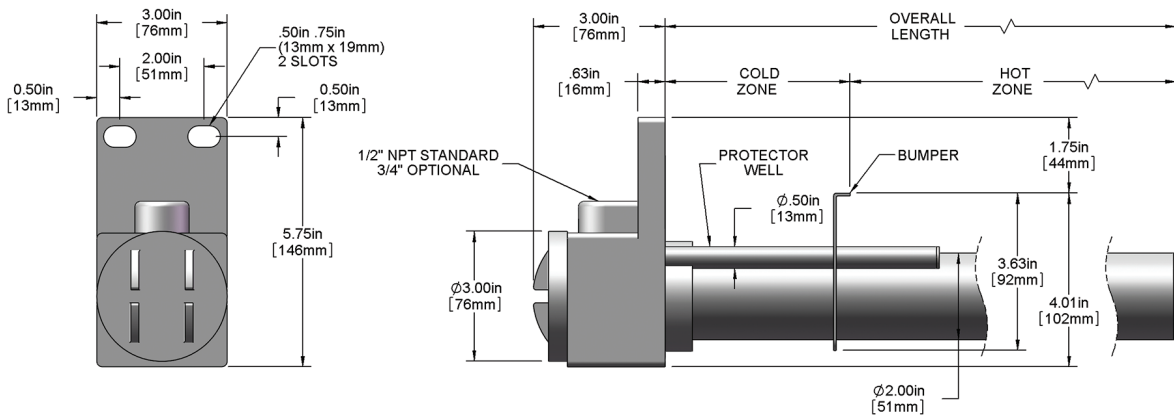

## MODEL NUMBER BREAKDOWN

Series	Wattage	Voltage	Overall Length	Phase	Type of Protector	Wire & Conduit Length
P = Steel	1 = 1000	1 = 120	11 = 1kW	Blank = single (std)	<b>Replaceable Fuse (Type-J TC)</b>	36" length standard (no designator)
F = 304 stainless steel	2 = 2000	2 = 240	17 = 2kW	-3 = 3 phase	P1 (std) = solutions up to 180°F	Specify variations from standard Ex: -X84 = 84"
S = 316 stainless steel	3 = 3000	3 = 380	23 = 3kW		P4 = solutions up to 230°F	
T = titanium	4 = 4000	4 = 480	29 = 4kW		P5 = solutions up to 300°F	
	5 = 5000	5 = 415	35 = 5kW		<b>Resettable Fuse (Type-J TC)</b>	
	6 = 6000	6 = 600	40 = 6kW		P2 = solutions up to 180°F	
	7 = 7000	7 = 400	47 = 8kW		P6 = solutions up to 230°F	
	8 = 8000	8 = 208	54 = 9kW		P7 = solutions up to 300°F	
	9 = 9000	9 = 220	59 = 10kW			
	10 = 10000	0 = 200	60 = 12kW			
	11 = 11000					
	12 = 12000					